

DS1489/DS1489A Quad Line Receiver

 Check for Samples: [DS1489](#), [DS1489A](#)

FEATURES

- Four Separate Receivers per Package
- Programmable Threshold
- Built-in Input Threshold Hysteresis
- “Fail Safe” Operating Mode: High Output for Open Inputs
- Inputs Withstand $\pm 30V$

DESCRIPTION

The DS1489/DS1489A are quad line receivers designed to interface data terminal equipment with data communications equipment. They are constructed on a single monolithic silicon chip. These devices satisfy the specifications of EIA Standard RS-232D. The DS1489/DS1489A meet and exceed the specifications of MC1489/MC1489A and are pin-for-pin replacements.

SCHEMATIC AND CONNECTION DIAGRAMS

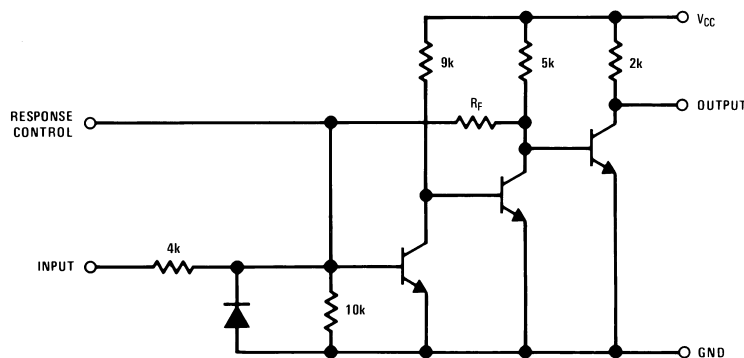

(1/4 of unit shown)

 DS1489: $R_F = 10k$

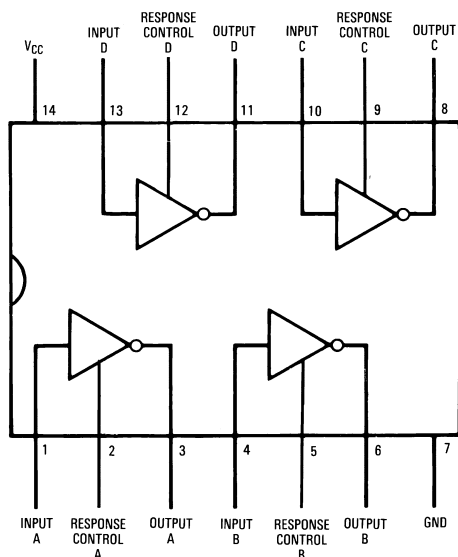
 DS1489A: $R_F = 2k$

**Dual-In-Line or Small-Out Line Package - Top View
PDIP/SOIC**

See Package Numbers NFF and D



Please be aware that an important notice concerning availability, standard warranty, and use in critical applications of Texas Instruments semiconductor products and disclaimers thereto appears at the end of this data sheet.

All trademarks are the property of their respective owners.



These devices have limited built-in ESD protection. The leads should be shorted together or the device placed in conductive foam during storage or handling to prevent electrostatic damage to the MOS gates.

AC TEST CIRCUIT AND VOLTAGE WAVEFORMS

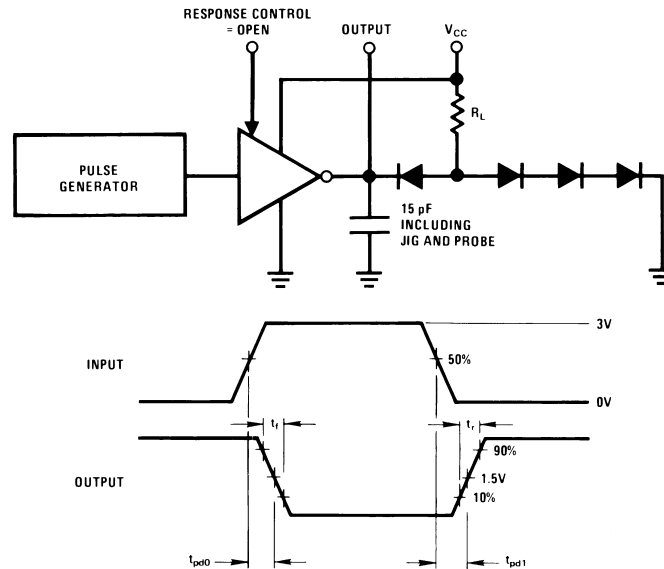

Figure 1.

ABSOLUTE MAXIMUM RATINGS (1)

If Military/Aerospace specified devices are required, contact the Texas Instruments Semiconductor Sales Office/ Distributors for availability and specifications.

Power Supply Voltage	10V
Input Voltage Range	±30V
Output Load Current	20 mA
Power Dissipation (2)	1W
Operating Temperature Range	0°C to +75°C
Storage Temperature Range	-65°C to +150°C
Maximum Power Dissipation at 25°C(3)	
Molded PDIP (NFF) Package	1207 mW
SOIC (D) Package	1042 mW
Lead Temperature (Soldering, 4 sec.)	260°C

- (1) "Absolute Maximum Ratings" are those values beyond which the safety of the device **cannot be** ensured. Except for "Operating Temperature Range" they are not meant to imply that the devices should be operated at these limits. The table of "Electrical Characteristics" provides conditions for actual device operation.
- (2) Unless otherwise specified min/max limits apply across the 0°C to +75°C temperature range for the DS1489 and DS1489A.
- (3) Derate molded PDIP package 9.7 mW/°C above 25°C; derate SOIC package 8.33 mW/°C above 25°C.

ELECTRICAL CHARACTERISTICS (1) (2) (3)

DS1489/DS1489A: The following apply for $V_{CC} = 5.0V \pm 1\%$, $0^{\circ}C \leq T_A \leq +75^{\circ}C$ unless otherwise specified.

Symbol	Parameter	Conditions		Min	Typ	Max	Units	
V_{TH}	Input High Threshold Voltage	$V_{OUT} \leq 0.45V$, $I_{OUT} = 10\text{ mA}$	DS1489	$T_A = 25^{\circ}C$	1.0	1.25	1.5	V
					0.9		1.6	
			DS1489A	$T_A = 25^{\circ}C$	1.75	2.00	2.25	V
						1.55		
V_{TL}	Input Low Threshold Voltage	$V_{OUT} \geq 2.5V$, $I_{OUT} = -0.5\text{ mA}$	$T_A = 25^{\circ}C$	0.75	1.00	1.25	V	
					0.65			1.35
I_{IN}	Input Current	$V_{IN} = +25V$		+3.6	+5.6	+8.3	mA	
		$V_{IN} = -25V$		-3.6	-5.6	-8.3	mA	
		$V_{IN} = +3V$		+0.43	+0.53		mA	
		$V_{IN} = -3V$		-0.43	-0.53		mA	
V_{OH}	Output High Voltage	$I_{OUT} = -0.5\text{ mA}$	$V_{IN} = 0.75V$		2.6	3.8	5.0	V
			Input = Open		2.6	3.8	5.0	V
V_{OL}	Output Low Voltage	$V_{IN} = 3.0V$, $I_{OUT} = 10\text{ mA}$			0.33	0.45	V	
I_{SC}	Output Short Circuit Current	$V_{IN} = 0.75V$			-3.0		mA	
I_{CC}	Supply Current	$V_{IN} = 5.0V$			14	26	mA	
P_d	Power Dissipation	$V_{IN} = 5.0V$			70	130	mW	

- (1) Unless otherwise specified min/max limits apply across the $0^{\circ}C$ to $+75^{\circ}C$ temperature range for the DS1489 and DS1489A.
- (2) All currents into device pins shown as positive, out of device pins as negative, all voltages referenced to ground unless otherwise noted. All values shown as max or min on absolute value basis.
- (3) These specifications apply for response control pin = open.

SWITCHING CHARACTERISTICS
 $V_{CC} = 5V$, $T_A = 25^{\circ}C$

Symbol	Parameter	Conditions	Min	Typ	Max	Units
t_{pd1}	Input to Output "High" Propagation Delay	$R_L = 3.9k$, (Figure 1) (AC Test Circuit)		28	85	ns
t_{pd0}	Input to Output "Low" Propagation Delay	$R_L = 390\Omega$, (Figure 1) (AC Test Circuit)		20	50	ns
t_r	Output Rise Time	$R_L = 3.9k$, (Figure 1) (AC Test Circuit)		110	175	ns
t_f	Output Fall Time	$R_L = 390\Omega$, (Figure 1) (AC Test Circuit)		9	20	ns

TYPICAL CHARACTERISTICS

$V_{CC} = 5.0V$, $T_A = +25^\circ C$ unless otherwise noted

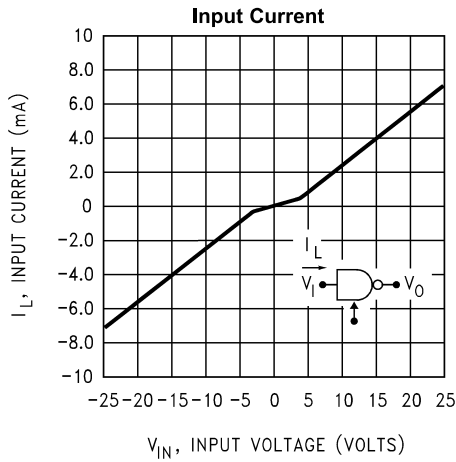

Figure 2.

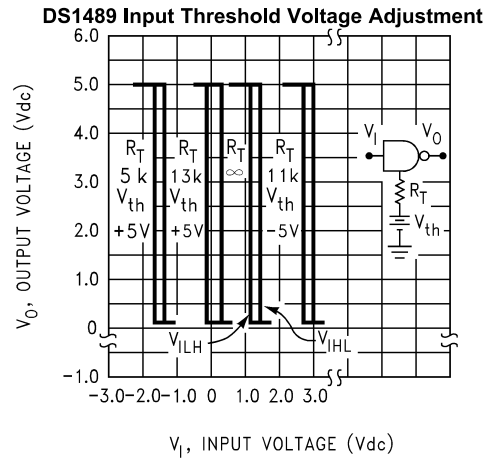

Figure 3.

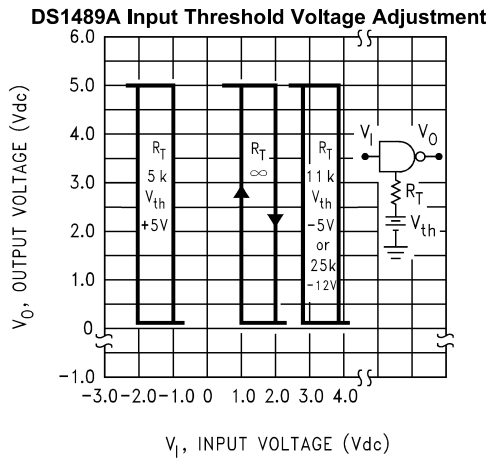

Figure 4.

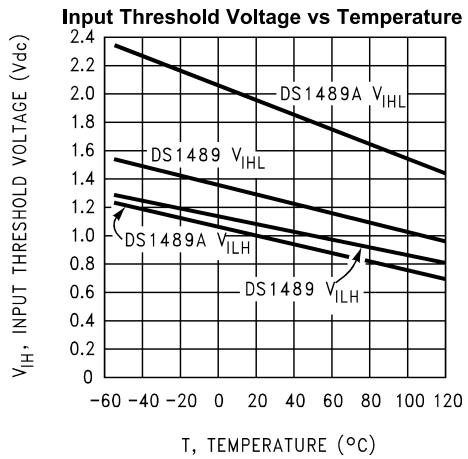

Figure 5.

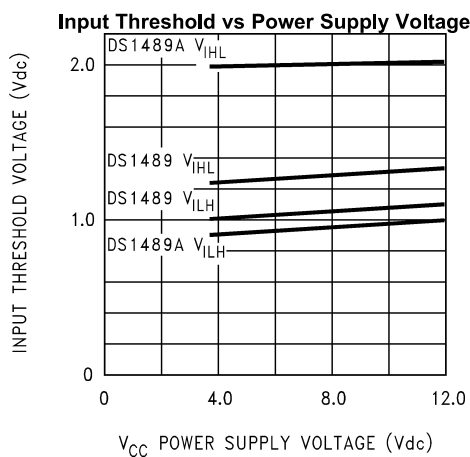

Figure 6.

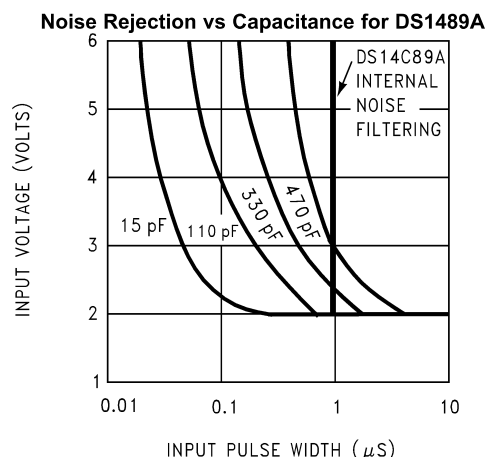
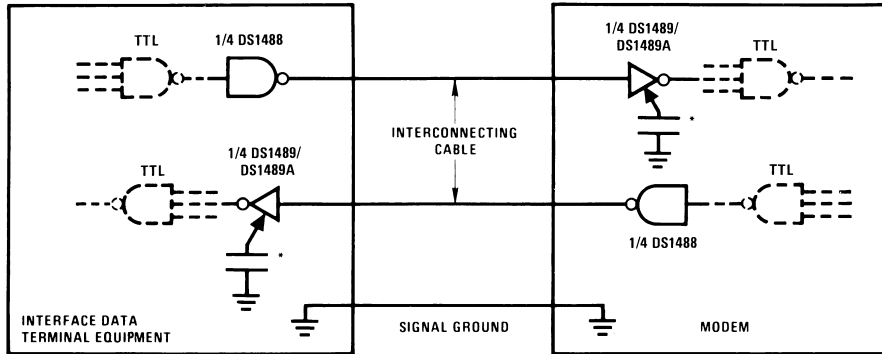

Figure 7.

TYPICAL APPLICATION INFORMATION



*Optional for noise filtering.

Figure 8. Applications Using the Response Control Pin

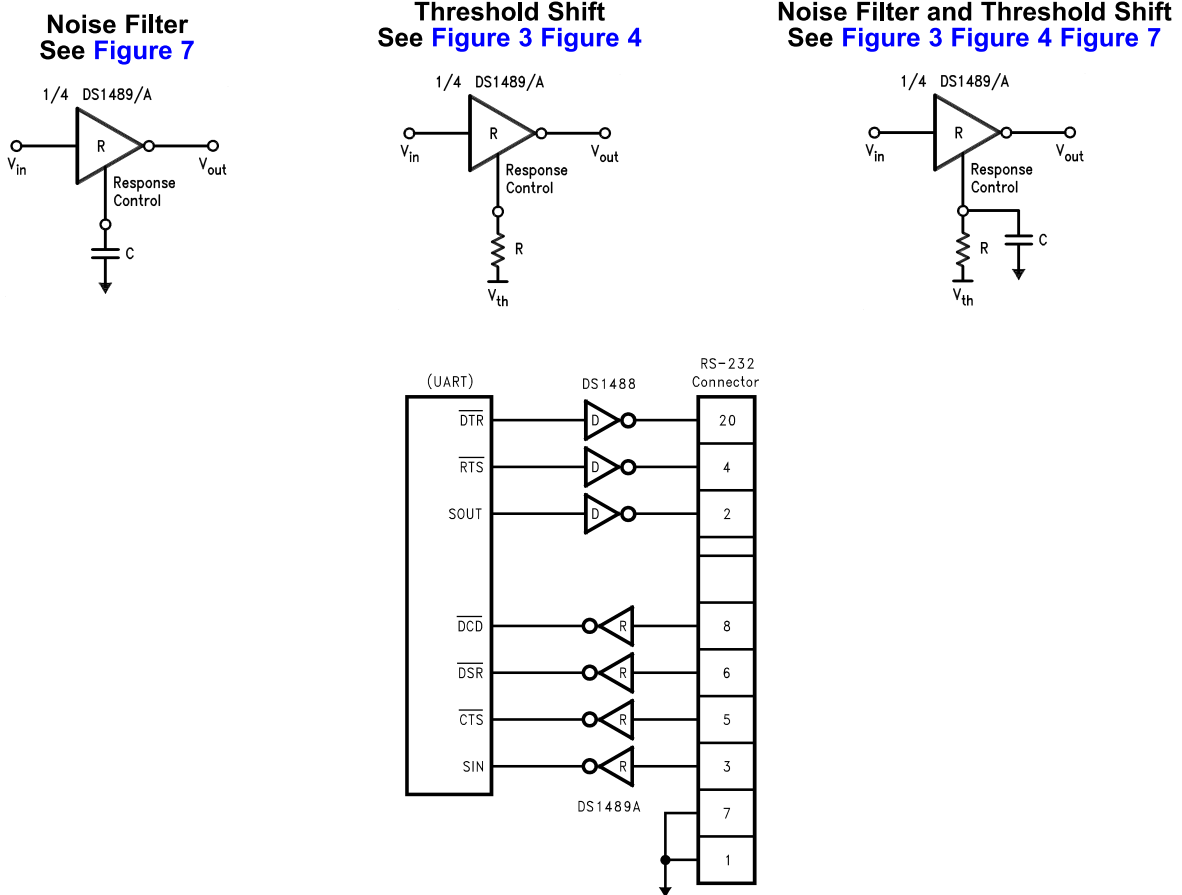

Figure 9. Application of DS1488, DS1489A and UART