

# SN55113, SN75113 DUAL DIFFERENTIAL LINE DRIVERS

SLLS070C – SEPTEMBER 1973 – REVISED MARCH 1997

- Choice of Open-Collector, Open-Emitter, or 3-State Outputs
- High-Impedance Output State for Party-Line Applications
- Single-Ended or Differential AND/NAND Outputs
- Single 5-V Supply
- Dual Channel Operation
- Compatible With TTL
- Short-Circuit Protection
- High-Current Outputs
- Common and Individual Output Controls
- Clamp Diodes at Inputs and Outputs
- Easily Adaptable to SN55114 and SN75114 Applications
- Designed for Use With SN55115 and SN75115

## description

The SN55113 and SN75113 dual differential line drivers with 3-state outputs are designed to provide all the features of the SN55114 and SN75114 line drivers with the added feature of driver output controls. Individual controls are provided for each output pair, as well as a common control for both output pairs. If any output is low, the associated output is in a high-impedance state and the output can neither drive nor load the bus. This permits many devices to be connected together on the same transmission line for party-line applications.

The output stages are similar to TTL totem-pole outputs, but with the sink outputs, YS and ZS, and the corresponding active pullup terminals, YP and ZP, available on adjacent package pins.

The SN55113 is characterized for operation over the full military temperature range of  $-55^{\circ}\text{C}$  to  $125^{\circ}\text{C}$ . The SN75113 is characterized for operation over the temperature range of  $0^{\circ}\text{C}$  to  $70^{\circ}\text{C}$ .

SN55113 ... J OR W PACKAGE  
SN75113 ... N PACKAGE  
(TOP VIEW)

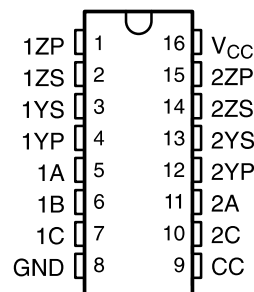

SN55113 ... FK PACKAGE  
(TOP VIEW)

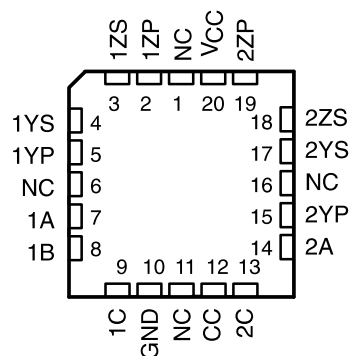

NC – No internal connection



Please be aware that an important notice concerning availability, standard warranty, and use in critical applications of Texas Instruments semiconductor products and disclaimers thereto appears at the end of this data sheet.

PRODUCTION DATA information is current as of publication date. Products conform to specifications per the terms of Texas Instruments standard warranty. Production processing does not necessarily include testing of all parameters.

 **TEXAS  
INSTRUMENTS**

POST OFFICE BOX 655303 • DALLAS, TEXAS 75265

Copyright © 1997, Texas Instruments Incorporated

# SN55113, SN75113 DUAL DIFFERENTIAL LINE DRIVERS

SLLS070C – SEPTEMBER 1973 – REVISED MARCH 1997

FUNCTION TABLE

		INPUTS		OUTPUTS	
OUTPUT C	CONTROL CC	DATA		AND Y	NAND Z
		A	B†		
L	X	X	X	Z	Z
X	L	X	X	Z	Z
H	H	L	X	L	H
H	H	X	L	L	H
H	H	H	H	H	L

H = high level, L = low level, X = irrelevant,

Z = high impedance (off)

† B input and 4th line of function table are applicable only to driver number 1.

## logic symbol‡

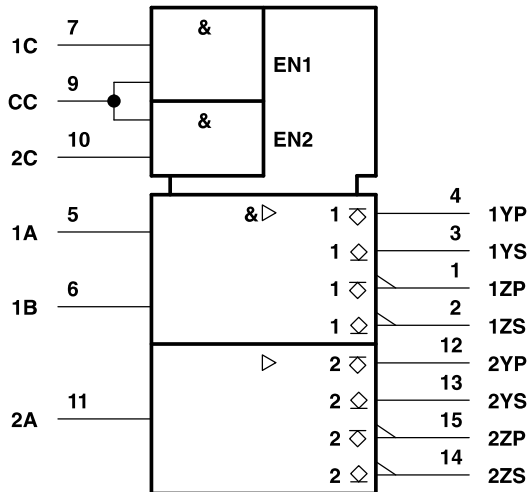

## logic diagram (positive logic)

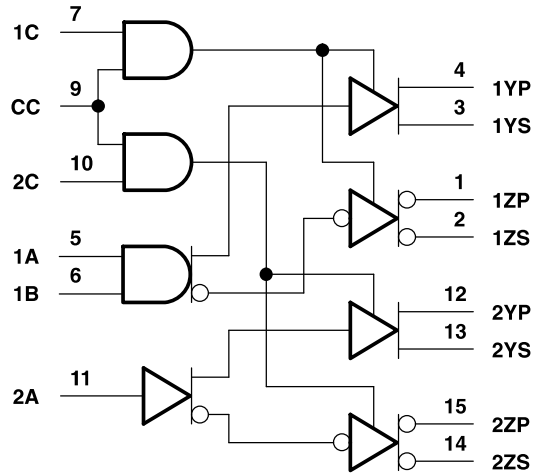

‡ This symbol is in accordance with ANSI/IEEE Std 91-1984 and IEC Publication 617-12.

Pin numbers shown are for the J, N, and W packages.

# SN55113, SN75113 DUAL DIFFERENTIAL LINE DRIVERS

SLLS070C – SEPTEMBER 1973 – REVISED MARCH 1997

## schematic

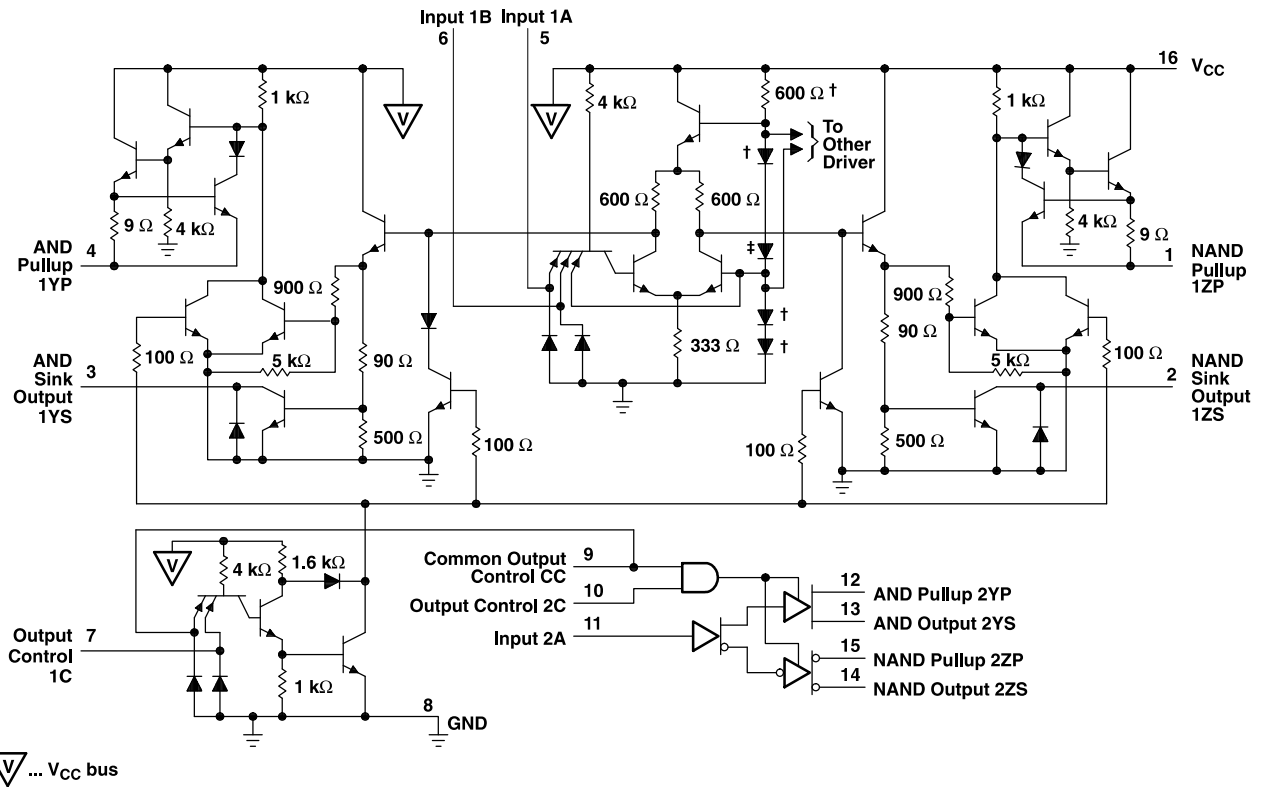

† These components are common to both drivers. Resistor values shown are nominal and in ohms.

## absolute maximum ratings over operating free-air temperature range (unless otherwise noted)‡

Supply voltage, $V_{CC}$ (see Note 1)	7 V
Input voltage, $V_I$	5.5 V
Off-state voltage applied to open-collector outputs	12 V
Continuous total power dissipation (see Note 2)	See Dissipation Rating Table
Operating free-air temperature range, $T_A$ : SN55113	-55°C to 125°C
SN75113	0°C to 70°C
Storage temperature range, $T_{stg}$	-65°C to 150°C
Lead temperature 1,6 mm (1/16 inch) from case for 10 seconds: N package	260°C
Case temperature for 60 seconds: FK package	260°C
Lead temperature 1,6 mm (1/16 inch) from case for 60 seconds: J or W package	300°C

‡ Stresses beyond those listed under "absolute maximum ratings" may cause permanent damage to the device. These are stress ratings only, and functional operation of the device at these or any other conditions beyond those indicated under "recommended operating conditions" is not implied. Exposure to absolute-maximum-rated conditions for extended periods may affect device reliability.

DISSIPATION RATING TABLE

PACKAGE	$T_A \leq 25^\circ\text{C}$ POWER RATING	DERATING FACTOR ABOVE $T_A = 25^\circ\text{C}$	$T_A = 70^\circ\text{C}$ POWER RATING	$T_A = 125^\circ\text{C}$ POWER RATING
FK	1375 mW	11.0 mW/°C	880 mW	275 mW
J	1375 mW	11.0 mW/°C	880 mW	275 mW
N	1150 mW	9.2 mW/°C	736 mW	N/A
W	1000 mW	8.0 mW/°C	640 mW	200 mW



POST OFFICE BOX 655303 • DALLAS, TEXAS 75265

# SN55113, SN75113 DUAL DIFFERENTIAL LINE DRIVERS

SLLS070C – SEPTEMBER 1973 – REVISED MARCH 1997

## recommended operating conditions

	SN55113			SN75113			UNIT
	MIN	NOM	MAX	MIN	NOM	MAX	
Supply voltage, $V_{CC}$	4.5	5	5.5	4.75	5	5.25	V
High-level input voltage, $V_{IH}$	2			2			V
Low-level input voltage, $V_{IL}$			0.8			0.8	V
High-level output current, $I_{OH}$			-40			-40	mA
Low-level output current, $I_{OL}$			40			40	mA
Operating free-air temperature, $T_A$	-55		125	0		70	°C

## electrical characteristics over recommended operating free-air temperature range (unless otherwise noted)

PARAMETER	TEST CONDITIONS†		SN55113			SN75113			UNIT
			MIN	TYP‡	MAX	MIN	TYP‡	MAX	
$V_{IK}$ Input clamp voltage	$V_{CC} = \text{MIN}$ , $I_I = -12 \text{ mA}$		-0.9	-1.5		-0.9	-1.5	V	
$V_{OH}$ High-level output voltage	$V_{CC} = \text{MIN}$ , $V_{IL} = 0.8 \text{ V}$	$V_{IH} = 2 \text{ V}$ , $I_{OH} = -10 \text{ mA}$	2.4	3.4		2.4	3.4	V	
		$I_{OH} = -40 \text{ mA}$	2	3.0		2	3.0		
$V_{OL}$ Low-level output voltage	$V_{CC} = \text{MIN}$ , $I_{OL} = 40 \text{ mA}$	$V_{IH} = 2 \text{ V}$ , $V_{IL} = 0.8 \text{ V}$	0.23	0.4		0.23	0.4	V	
$V_{OK}$ Output clamp voltage	$V_{CC} = \text{MAX}$ , $I_O = -40 \text{ mA}$		-1.1	-1.5		-1.1	-1.5	V	
$I_{O(\text{off})}$ Off-state open-collector output current	$V_{CC} = \text{MAX}$	$V_{OH} = 12 \text{ V}$	$T_A = 25^\circ\text{C}$		1	10		$\mu\text{A}$	
			$T_A = 125^\circ\text{C}$		200				
		$V_{OH} = 5.25 \text{ V}$	$T_A = 25^\circ\text{C}$			1	10		
			$T_A = 70^\circ\text{C}$		20				
$I_{OZ}$ Off-state (high-impedance-state) output current	$V_{CC} = \text{MAX}$ , Output controls at 0.8 V	$T_A = \text{MAX}$	$T_A = 25^\circ\text{C}$ , $V_O = 0 \text{ to } V_{CC}$		$\pm 10$		$\pm 10$	$\mu\text{A}$	
			$V_O = 0$		-150		-20		
			$V_O = 0.4 \text{ V}$		$\pm 80$		$\pm 20$		
			$V_O = 2.4 \text{ V}$		$\pm 80$		$\pm 20$		
			$V_O = V_{CC}$		80		20		
$I_I$ Input current at maximum input voltage	A, B, C	$V_{CC} = \text{MAX}$ , $V_I = 5.5 \text{ V}$	1			1			mA
	CC		2			2			
$I_{IH}$ High-level input current	A, B, C	$V_{CC} = \text{MAX}$ , $V_I = 2.4 \text{ V}$	40			40			$\mu\text{A}$
	CC		80			80			
$I_{IL}$ Low-level input current	A, B, C	$V_{CC} = \text{MAX}$ , $V_I = 0.4 \text{ V}$	-1.6			-1.6			mA
	CC		-3.2			-3.2			
$I_{OS}$ Short-circuit output current§	$V_{CC} = \text{MAX}$ , $V_O = 0$ , $T_A = 25^\circ\text{C}$		-40	-90	-120	-40	-90	-120	mA
$I_{CC}$ Supply current (both drivers)	All inputs at 0 V, No load, $T_A = 25^\circ\text{C}$		$V_{CC} = \text{MAX}$		47	65	47	65	mA
			$V_{CC} = 7 \text{ V}$		65	85	65	85	

† All parameters with the exception of off-state open-collector output current are measured with the active pullup connected to the sink output. For conditions shown as MIN or MAX, use the appropriate value specified under recommended operating conditions.

‡ All typical values are at  $T_A = 25^\circ\text{C}$  and  $V_{CC} = 5 \text{ V}$ , with the exception of  $V_{CC}$  at 7 V.

§ Only one output should be shorted at a time, and duration of the short-circuit should not exceed one second.



POST OFFICE BOX 655303 • DALLAS, TEXAS 75265

# SN55113, SN75113 DUAL DIFFERENTIAL LINE DRIVERS

SLLS070C – SEPTEMBER 1973 – REVISED MARCH 1997

switching characteristics,  $V_{CC} = 5\text{ V}$ ,  $C_L = 30\text{ pF}$ ,  $T_A = 25^\circ\text{C}$

PARAMETER	TEST CONDITIONS	SN55113			SN75113			UNIT
		MIN	TYP	MAX	MIN	TYP	MAX	
$t_{PLH}$	Propagation delay time, low-to-high level output		13	20		13	30	ns
$t_{PHL}$	Propagation delay time, high-to-low-level output		12	20		12	30	ns
$t_{PZH}$	Output enable time to high level	$R_L = 180\ \Omega$ , See Figure 2	7	15		7	20	ns
$t_{PZL}$	Output enable time to low level	$R_L = 250\ \Omega$ , See Figure 3	14	30		14	40	ns
$t_{PHZ}$	Output disable time from high level	$R_L = 180\ \Omega$ , See Figure 2	10	20		10	30	ns
$t_{PLZ}$	Output disable time from low level	$R_L = 250\ \Omega$ , See Figure 3	17	35		17	35	ns

## PARAMETER MEASUREMENT INFORMATION

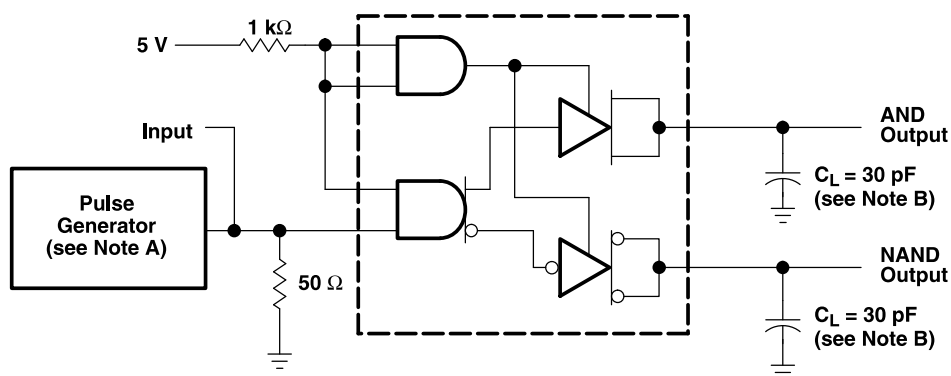

TEST CIRCUIT

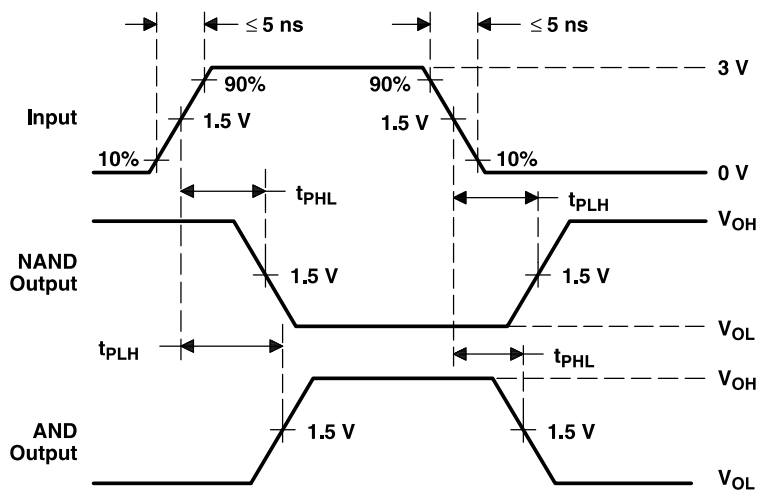

VOLTAGE WAVEFORMS

- NOTES: A. The pulse generator has the following characteristics:  $Z_O = 50\ \Omega$ ,  $PRR \leq 500\text{ kHz}$ ,  $t_w = 100\text{ ns}$ .  
 B.  $C_L$  includes probe and jig capacitance.

**Figure 1. Test Circuit and Voltage Waveforms  $t_{PLH}$  and  $t_{PHL}$**



# SN55113, SN75113 DUAL DIFFERENTIAL LINE DRIVERS

SLLS070C – SEPTEMBER 1973 – REVISED MARCH 1997

## PARAMETER MEASUREMENT INFORMATION

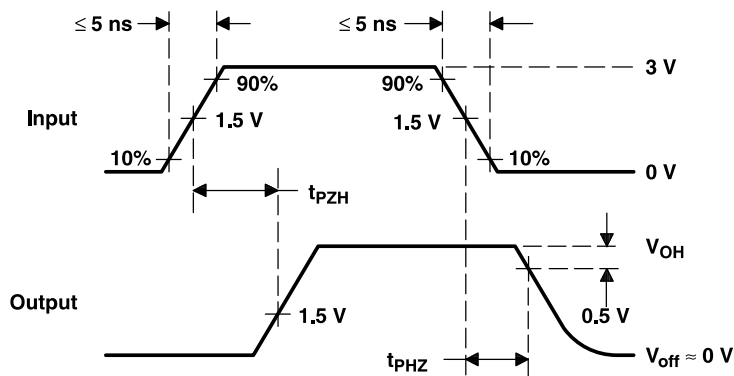
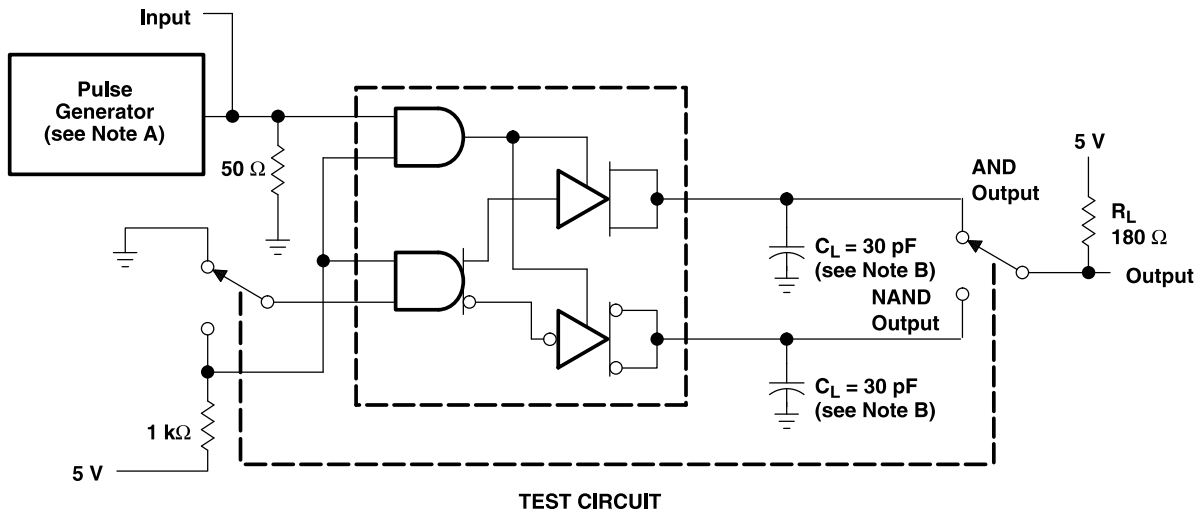

VOLTAGE WAVEFORMS

- NOTES: A. The pulse generator has the following characteristics:  $Z_O = 50\ \Omega$ ,  $PRR \leq 500\text{ kHz}$ ,  $t_w = 100\text{ ns}$ .  
B.  $C_L$  includes probe and jig capacitance.

Figure 2. Test Circuit and Voltage Waveforms  $t_{pZH}$  and  $t_{pHZ}$

PARAMETER MEASUREMENT INFORMATION

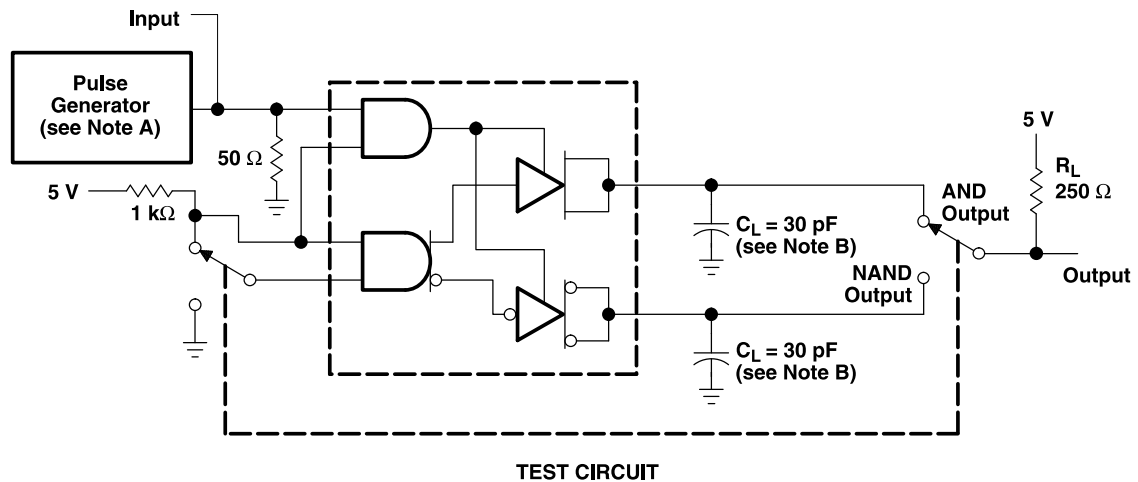

TEST CIRCUIT

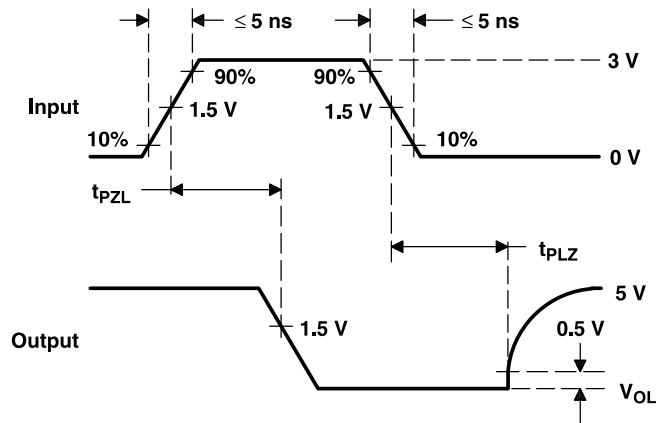

VOLTAGE WAVEFORMS

NOTES: A. The pulse generator has the following characteristics:  $Z_O = 50 \Omega$ ,  $PRR \leq 500 \text{ kHz}$ ,  $t_w = 100 \text{ ns}$ .  
B.  $C_L$  includes probe and jig capacitance.

Figure 3. Test Circuit and Voltage Waveforms,  $t_{pZL}$  and  $t_{pLZ}$

# SN55113, SN75113 DUAL DIFFERENTIAL LINE DRIVERS

SLLS070C – SEPTEMBER 1973 – REVISED MARCH 1997

## TYPICAL CHARACTERISTICS†

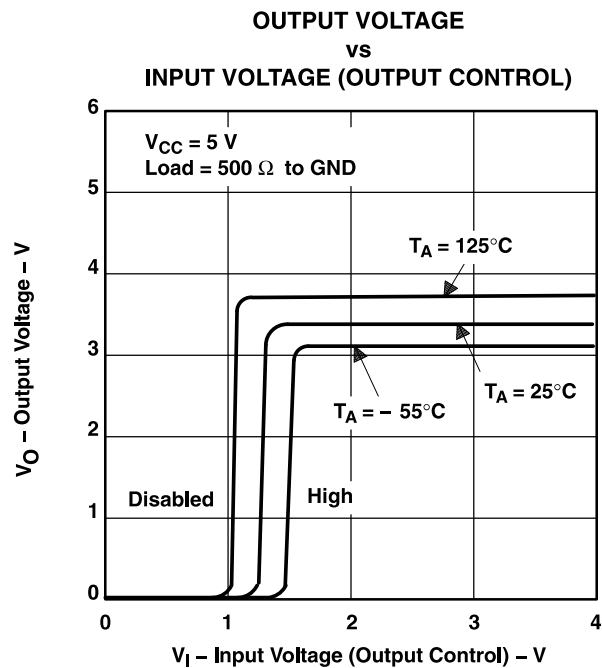
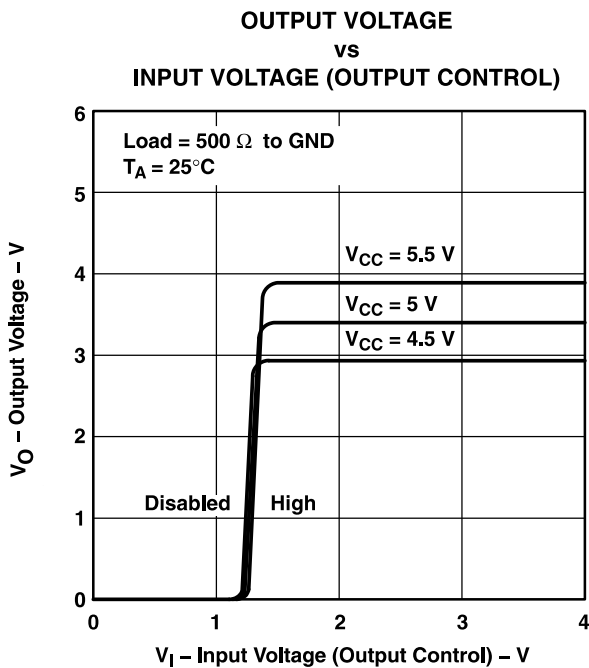
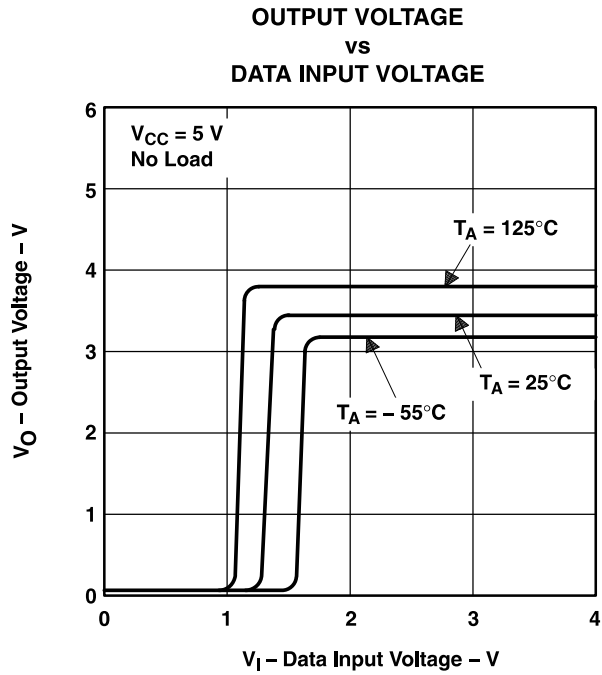
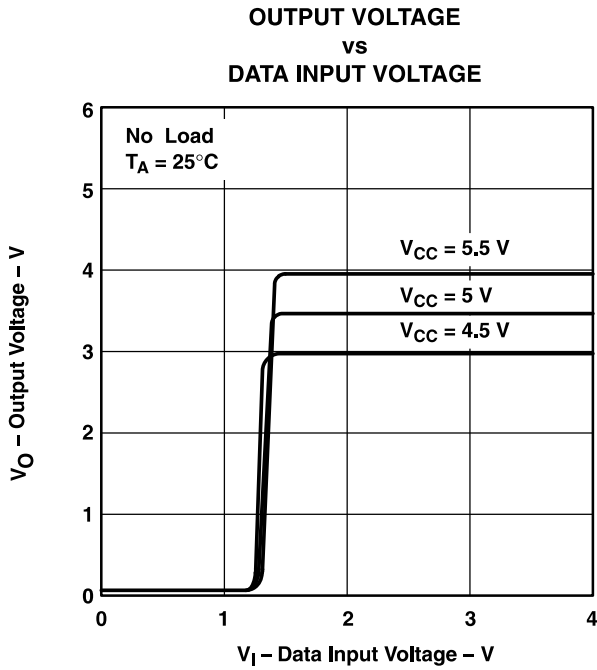

† Data for temperatures below 0°C and above 70°C and for supply voltages below 4.75 V and above 5.25 V are applicable to SN55113 circuits only. These parameters were measured with the active pullup connected to the sink output.



TYPICAL CHARACTERISTICS†

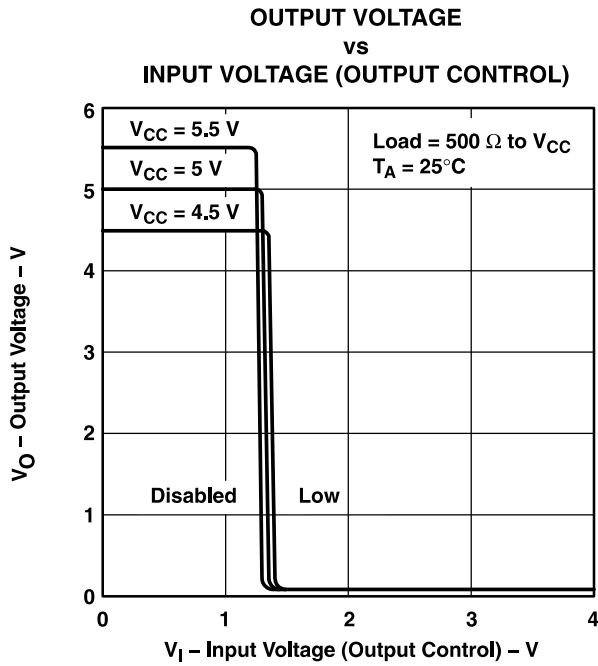

Figure 8

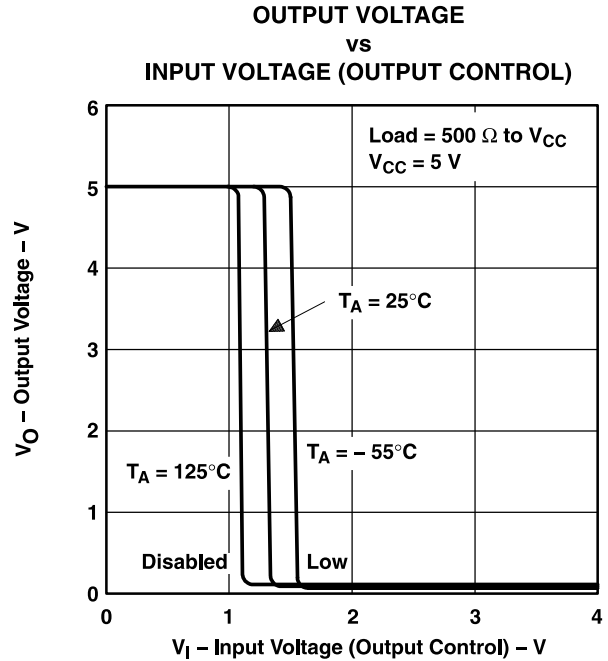

Figure 9

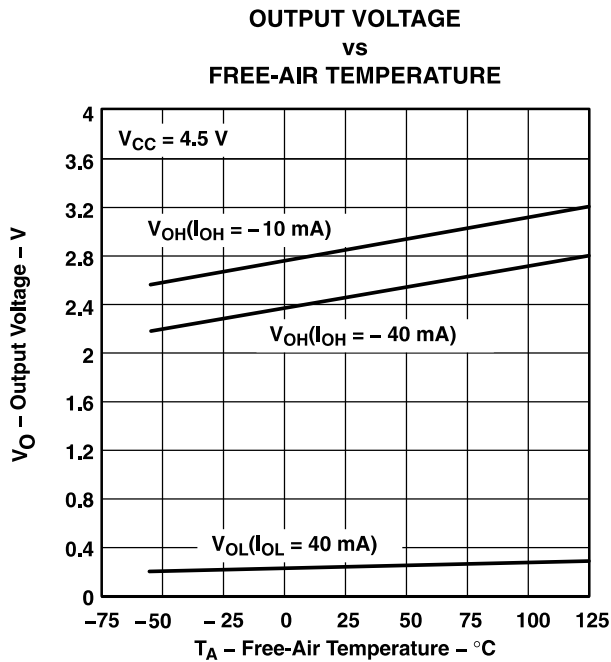

Figure 10

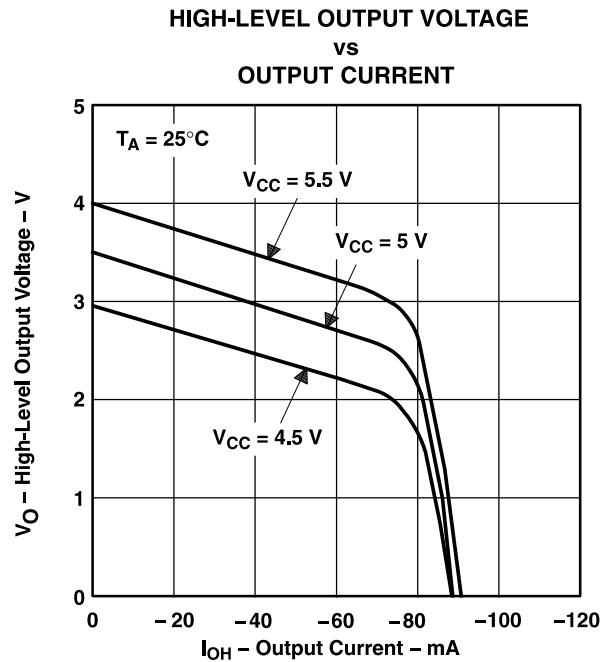

Figure 11

† Data for temperatures below  $0^\circ\text{C}$  and above  $70^\circ\text{C}$  and for supply voltages below  $4.75\text{ V}$  and above  $5.25\text{ V}$  are applicable to SN55113 circuits only. These parameters were measured with the active pullup connected to the sink output.

# SN55113, SN75113 DUAL DIFFERENTIAL LINE DRIVERS

SLLS070C – SEPTEMBER 1973 – REVISED MARCH 1997

## TYPICAL CHARACTERISTICS†

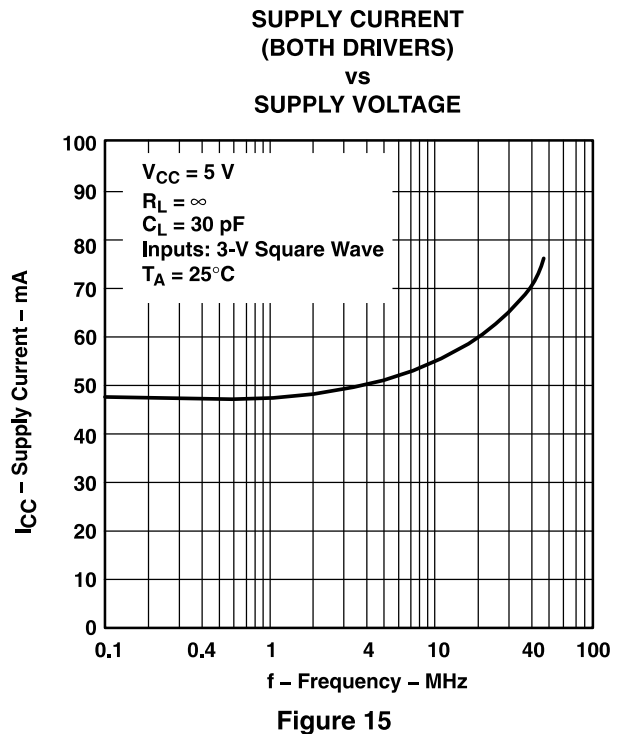
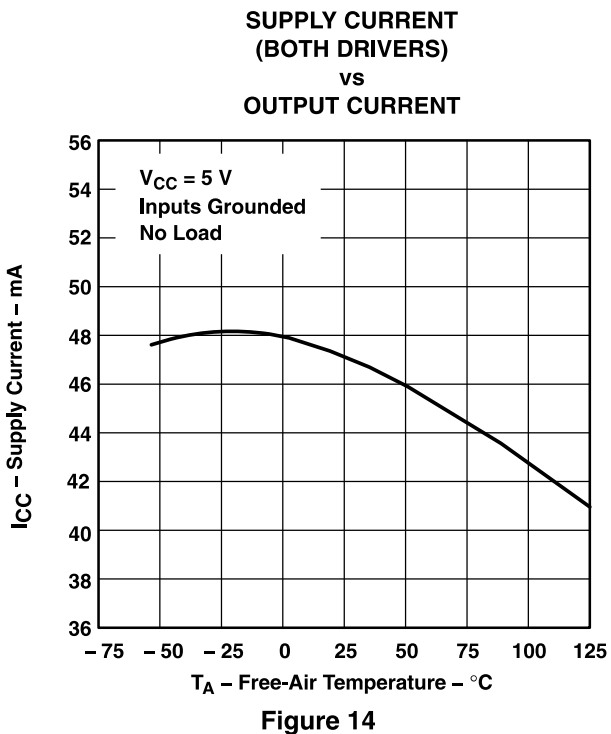
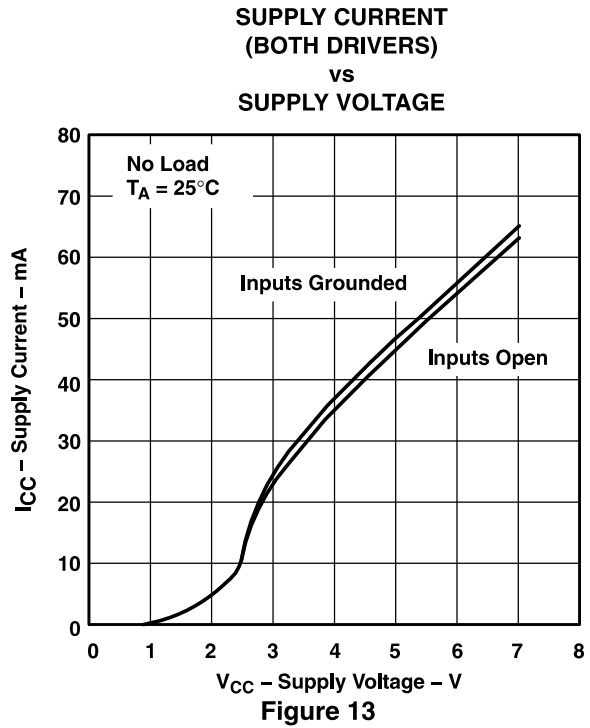
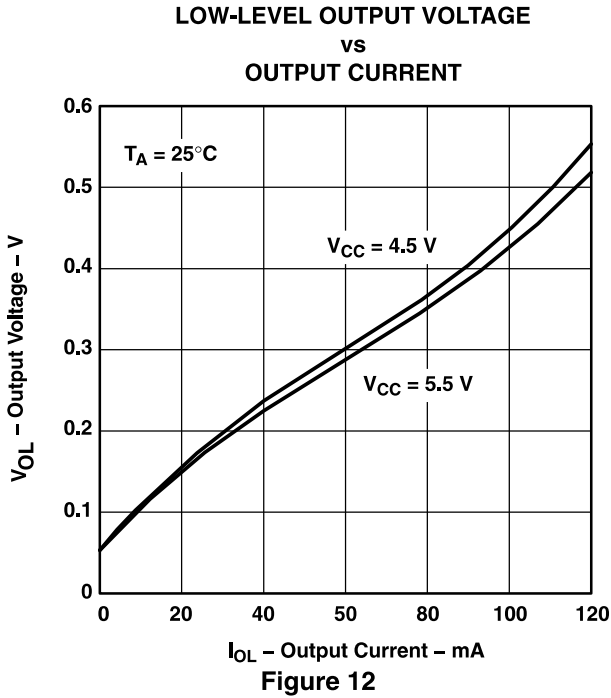

† Data for temperatures below 0°C and above 70°C and for supply voltages below 4.75 V and above 5.25 V are applicable to SN55113 circuits only. These parameters were measured with the active pullup connected to the sink output.

# SN55113, SN75113 DUAL DIFFERENTIAL LINE DRIVERS

SLLS070C – SEPTEMBER 1973 – REVISED MARCH 1997

## TYPICAL CHARACTERISTICS†

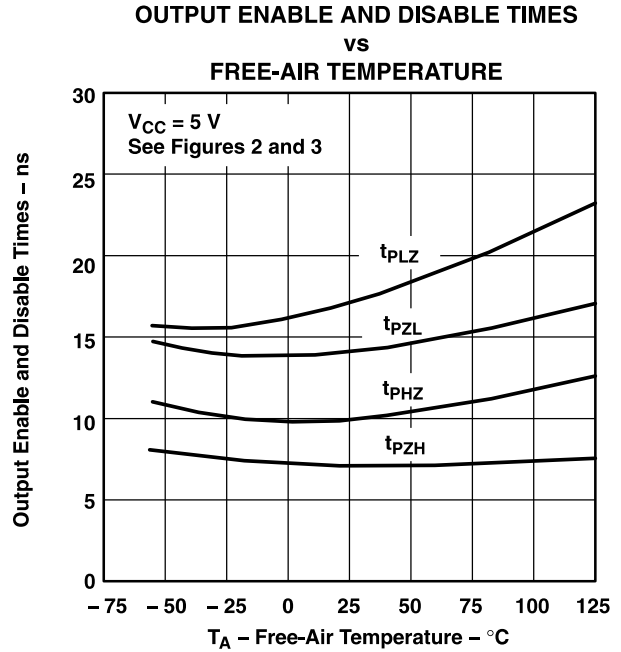
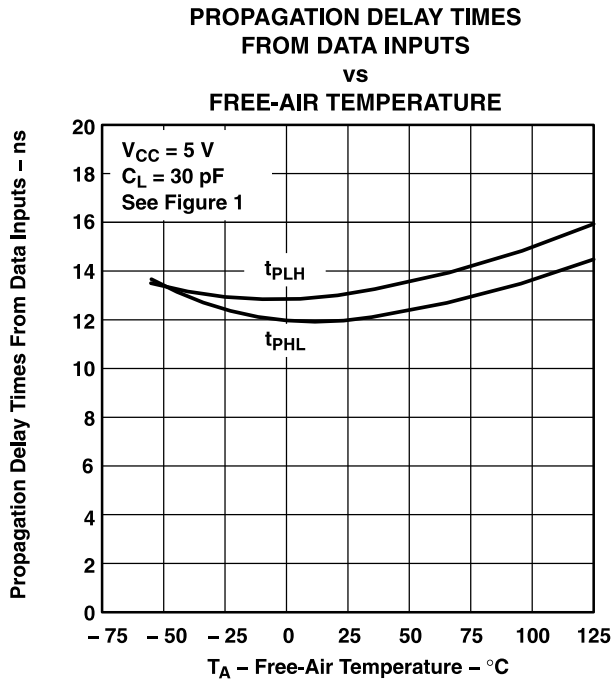

† Data for temperatures below 0°C and above 70°C and for supply voltages below 4.75 V and above 5.25 V are applicable to SN55113 circuits only. These parameters were measured with the active pullup connected to the sink output.

## APPLICATION INFORMATION

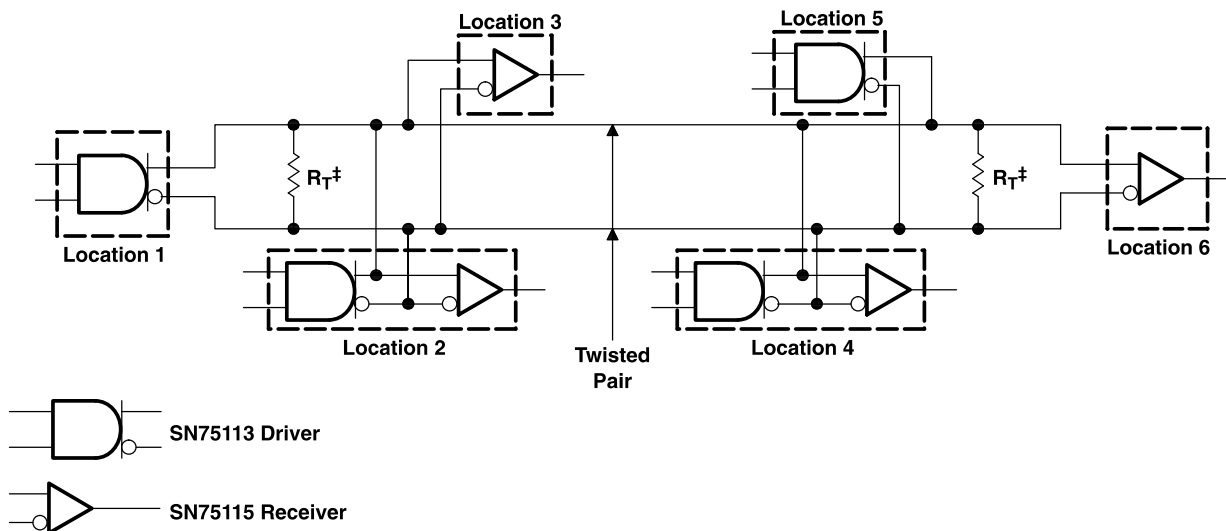

†  $R_T = Z_0$ . A capacitor may be connected in series with  $R_T$  to reduce power dissipation.

**Figure 18. Basic Party-Line or Data-Bus Differential Data Transmission**

# MECHANICAL DATA

## N (R-PDIP-T\*\*)

16 PINS SHOWN

## PLASTIC DUAL-IN-LINE PACKAGE

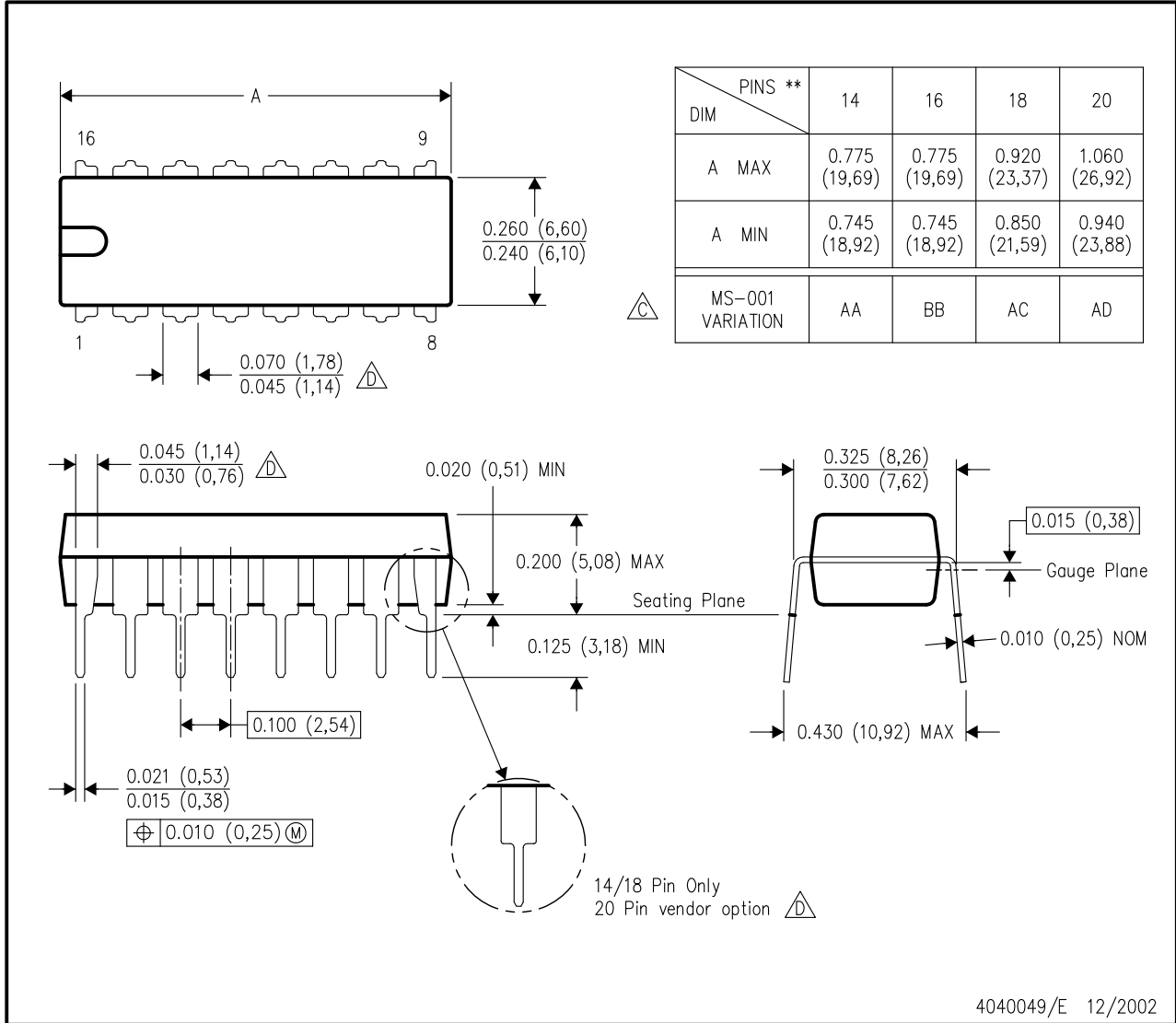

4040049/E 12/2002

- NOTES:
- A. All linear dimensions are in inches (millimeters).
  - B. This drawing is subject to change without notice.
  - Falls within JEDEC MS-001, except 18 and 20 pin minimum body length (Dim A).
  - The 20 pin end lead shoulder width is a vendor option, either half or full width.